

Three Phase Theory - Professor J R Lucas

As you are aware, to transmit power with single phase alternating current, we need two wires (live wire and neutral). However you would have seen that distribution lines usually have only 4 wires. This is because distribution is done using three phase and the 4th wire is the neutral. How does this help ? Since the three phases are usually 120° out of phase, their phasor addition will be zero if the supply is balanced.

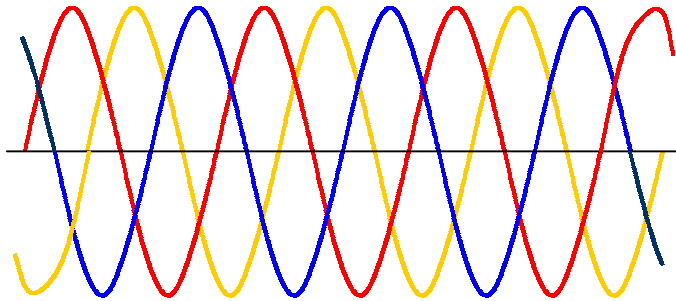

Figure 1(a) – Three phase waveforms

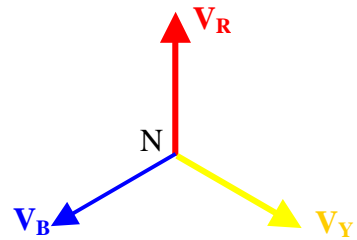

Figure 1(b) Phasor Diagram

It is seen from figure 1(a) that in the balanced system shown, the three phases, usually designated R, Y, B corresponding to Red, Yellow and Blue, are equal in magnitude and differ in phase angle by 120° . The corresponding phasor diagram is shown in figure 1(b).

The voltage between any of the phases and the neutral is called the phase-to-neutral voltage or **phase voltage** V_p .

It is usual to call the voltage between any two lines as the line-to-line voltage or **line voltage** V_L .

If the R-phase voltage is $V_R = V_p \angle 0$, then the remaining phase voltages would be $V_Y = V_p \angle -2\pi/3$ and $V_B = V_p \angle -4\pi/3$.

Balanced Supply

A balanced three phase supply can be connected either in **star** as in figure 2 (a) or in **delta** as in figure 2 (b).

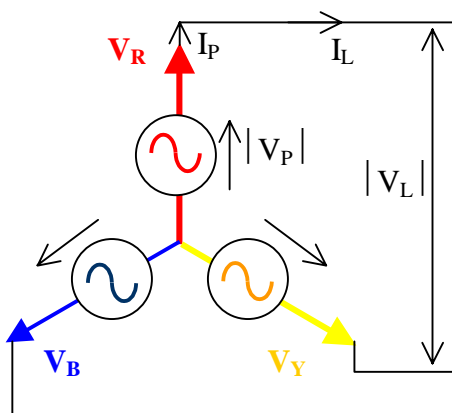

Figure 2(a) Star-connected supply

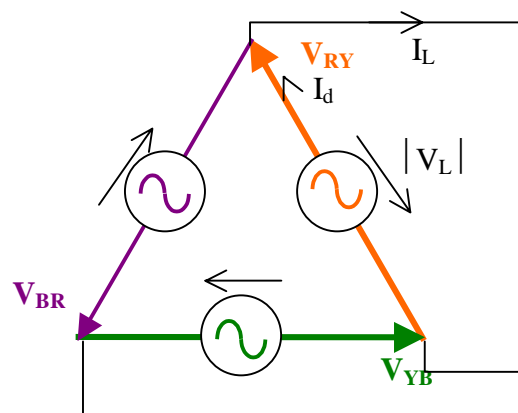

Figure 2(b) Delta-connected supply

In a balanced three phase system, knowledge of one of the phases gives the other two phases directly. However this is not the case for an unbalanced supply.

In a star connected supply, it can be seen that the line current (current in the line) is equal to the phase current (current in a phase). However, the line voltage is not equal to the phase voltage.

The line voltages are defined as $V_{RY} = V_R - V_Y$, $V_{YB} = V_Y - V_B$, and $V_{BR} = V_B - V_R$.

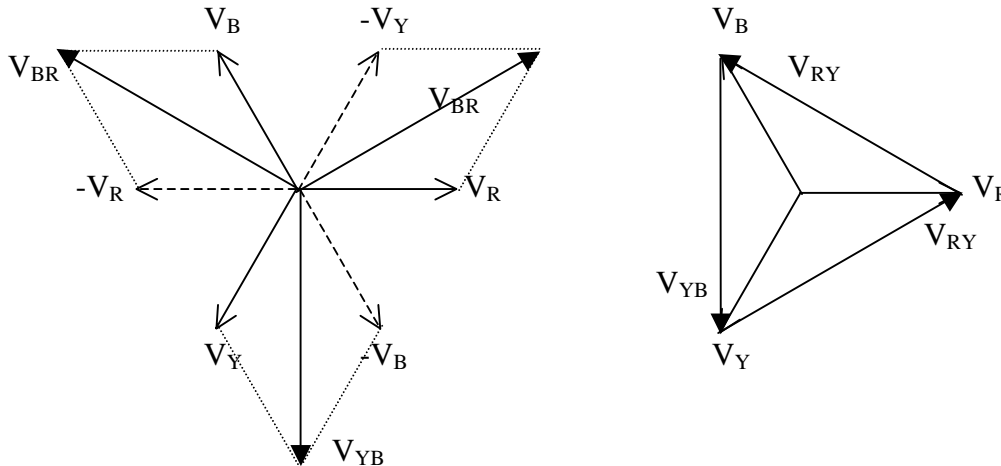

Figure 3(a) Parallelogram addition

Figure 3(b) Triangular addition

Figure 3(a) shows how the line voltage may be obtained using the normal parallelogram addition. It can also be seen that triangular addition also gives the same result faster.

For a balanced system, the angles between the phases is 120° and the magnitudes are all equal. Thus the line voltages would be 30° leading the nearest phase voltage. Calculation will easily show that the magnitude of the line voltage is $\sqrt{3}$ times the phase voltage.

$$I_L = I_p , \quad |V_L| = \sqrt{3} |V_p| , \quad |I_L| = \sqrt{3} |I_d|$$

Similarly in the case of a delta connected supply, the current in the line is $\sqrt{3}$ times the current in the delta.

It is important to note that the three line voltages in a balanced three phase supply is also 120° out of phase, and for this purpose, the line voltages must be specified in a sequential manner. i.e. V_{RY} , V_{YB} and V_{BR} . [Note: V_{BY} is 180° out of phase with V_{YB} so that the corresponding angles if this is chosen may appear to be 60° rather than 120°].

Thus if the direction of V_R is selected as reference, then

$$V_R = V_p \angle 0, \quad V_Y = V_p \angle -2\pi/3 \quad \text{and} \quad V_B = V_p \angle -4\pi/3$$

$$\text{and} \quad V_{RY} = \sqrt{3} V_p \angle \pi/6, \quad V_{YB} = \sqrt{3} V_p \angle -\pi/2 \quad \text{and} \quad V_{BR} = \sqrt{3} V_p \angle -7\pi/6$$

Balanced Load

A balanced load would have the impedances of the three phase equal in magnitude and in phase. Although the three phases would have the phase angles differing by 120° in a balanced supply, the current in each phase would also have phase angles differing by 120° with balanced currents. Thus if the current is lagging (or leading) the corresponding voltage by a particular angle in one phase, then it would lag (or lead) by the same angle in the other two phases as well (Figure 4(a)).

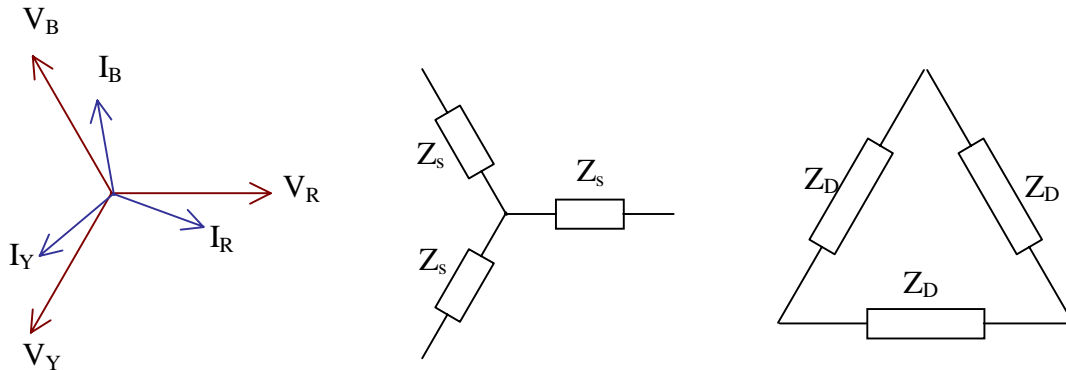

Figure 4(a) Phasor Diagram Figure 4(b) Star connection Figure 4(c) Delta connection

The balanced load can take one of two configurations – star connection, or delta connection. For the same load, star connected impedance and the delta connected impedance will not have the same value. However in both cases, each of the three phase will have the same impedance as shown in figures 4(b) and 4 (c).

It can be shown, for a balanced load (using the star delta transformation or otherwise), that the equivalent delta connected impedance is 3 times that of the star connected impedance. The phase angle of the impedance is the same in both cases.

$$Z_D = 3 Z_s.$$

Note: This can also be remembered in this manner. In the delta, the voltage is $\sqrt{3}$ times larger and the current $\sqrt{3}$ times smaller, giving the impedance 3 times larger. It is also seen that the equivalent power is unaffected by this transformation.

Three Phase Power

In the case of single phase, we learnt that the active power is given by

$$P = V I \cos \phi$$

In the case of three phase, obviously this must apply for each of the three phases. Thus

$$P = 3 V_p I_p \cos \phi$$

However, in the case of three phase, the neutral may not always be available for us to measure the phase voltage. Also in the case of a delta, the phase current would actually be the current inside the delta which may also not be directly available.

It is usual practice to express the power associated with three phase in terms of the line quantities. Thus we will first consider the star connected load and the delta connected load independently.

For a balanced **star** connected load with line voltage V_L and line current I_L ,

$$V_{\text{star}} = V_L / \sqrt{3}, \quad I_{\text{star}} = I_L$$

$$Z_{\text{star}} = V_{\text{star}} / I_{\text{star}} = V_L / \sqrt{3} I_L$$

$$S_{\text{star}} = 3 V_{\text{star}} I_{\text{star}}^* = \sqrt{3} V_L I_L^*$$

Thus $P_{\text{star}} = \sqrt{3} V_L I_L \cos \phi$, $Q_{\text{star}} = \sqrt{3} V_L I_L \sin \phi$

For a balanced **delta** connected load with line voltage V_{line} and line current I_{line}

$$V_{\text{delta}} = V_L, \quad I_{\text{delta}} = I_L / \sqrt{3}$$

$$Z_{\text{delta}} = V_{\text{delta}} / I_{\text{delta}} = \sqrt{3} V_L / I_L$$

$$S_{\text{delta}} = 3 V_{\text{delta}} I_{\text{delta}} = \sqrt{3} V_L I_L$$

Thus $P_{\text{star}} = \sqrt{3} V_L I_L \cos \phi$, $Q_{\text{star}} = \sqrt{3} V_L I_L \sin \phi$

It is worth noting here, that although the currents and voltages inside the star connected load and the delta connected loads are different, the expressions for apparent power, active power and reactive power are the same for both types of loads when expressed in terms of the line quantities.

Thus for a three phase system (in fact we do not even have to know whether it is a load or not, or whether it is star-connected or delta-connected)

Apparent Power	$S = \sqrt{3} V_L I_L$
Active Power	$P = \sqrt{3} V_L I_L \cos \phi$
Reactive Power	$Q = \sqrt{3} V_L I_L \sin \phi$

Analysis of three phase balanced systems

Since we know that the three phases are balanced and that the voltages (and currents) are related to each other by 120° , we do not have to do calculations for each of the three phases unnecessarily. We could calculate for just one phase (usually the A phase in a system with phase sequence A-B-C). There are two common methods of doing this.

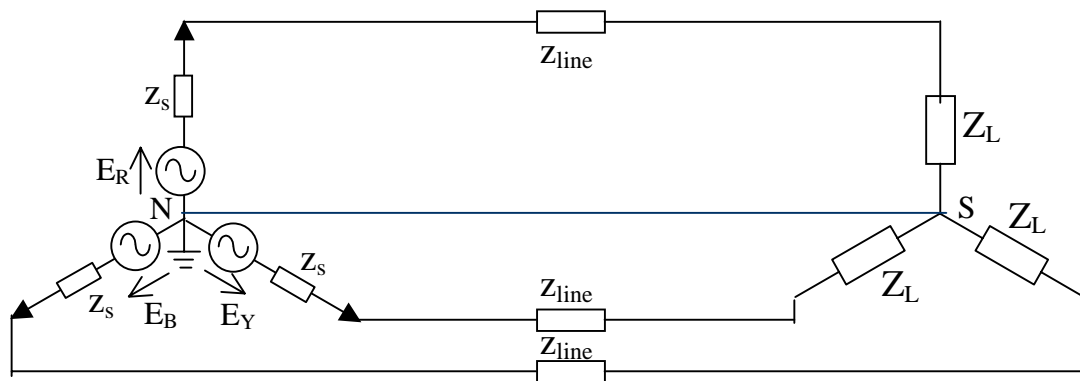

Figure 5 – Three phase system

(a) Single circuit of a three phase system

Consider the 3 phase 3 wire system shown in figure 5 (with the neutral wire absent). For a balanced system, the supply voltages E_R , E_Y and E_B will be 120° out of phase.

Using Millmann's theorem (or otherwise), it can be easily seen that the potential of the star point S of the load is equal to the potential of the neutral N of the supply. Thus whether a neutral wire is present or not in the system, the analysis of the system can be identical. Thus we will draw a neutral wire between S and N of zero impedance and do our analysis in that manner.

Once the neutral wire is in place, and there is no potential difference between S and N, we could analyse only one single phase of the system, namely the "A" phase. This may be redrawn as in figure 6.

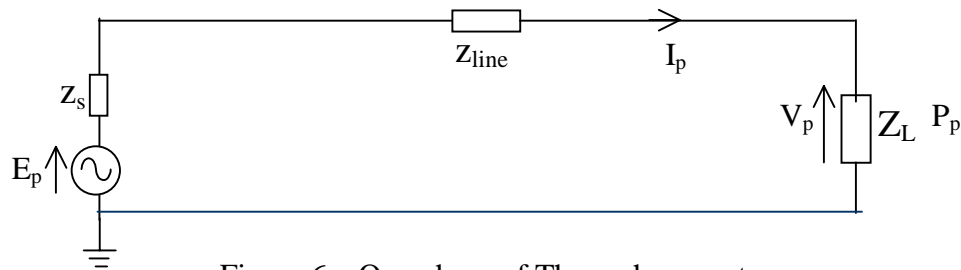

Figure 6 – One phase of Three phase system

In this case, the supply voltage E_p is a phase voltage, the supply current is the phase current I_p , the load voltage V_p is a phase voltage and the power P_p is the power in one phase.

If we compare with the line quantities, we have

$$E_L = \sqrt{3} E_p, \quad I_L = I_p \quad \text{and} \quad P_p = P/3$$

Usually, we are more interested in knowing the voltage and the power from practical considerations, rather than the current. [For example, if I ask you the voltage and power rating of a bulb in your home, you would know it. However if I asked you for the current taken by the bulb, you would normally not be aware of the value but would probably obtain it from the wattage and the voltage. The same is true in a large power system].

Thus we would like to reformulate the problem so as to give the voltage and the power at the desired values, even at the expense of a wrong current.

(b) Equivalent circuit for three phase balanced system

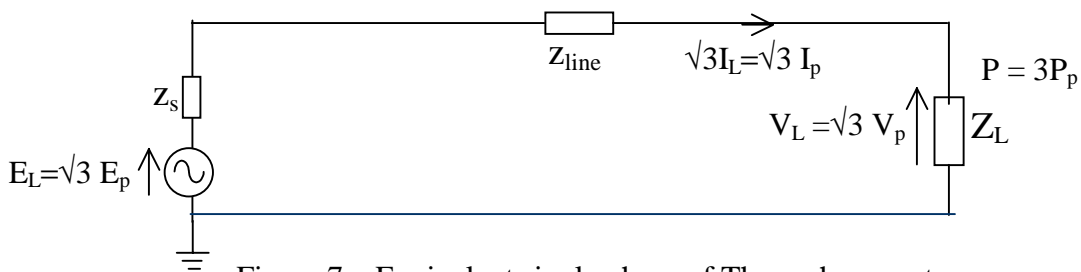

Figure 7 – Equivalent single phase of Three phase system

Consider multiplying the source voltage E_p in figure 6 by $\sqrt{3}$. This would increase both the line current I_p and the load voltage V_p by a factor of $\sqrt{3}$.

Since both the load voltage and the load current has increased by $\sqrt{3}$ times, the load power would increase $\sqrt{3} \times \sqrt{3}$ or 3 times.

Thus we see that such a circuit (figure 7) would have all voltages corresponding to the line voltages, and all powers corresponding to the total three phase powers as desired. The only quantity that would be in error is the line current which would appear as a current $\sqrt{3}$ times too high.

This circuit is known as the equivalent single phase diagram and gives the voltage and power as for the three phase system but with the current being in error by $\sqrt{3}$ times.

Let us consider an example to illustrate the use of the circuits.

Example

A three phase 400V, 50 Hz, balanced supply feeds a balanced load consisting of (a) three equal single phase loads of $(40 + j 30) \Omega$ connected in star, and (b) a three phase heating load (purely resistive) of 1.8 kW.

Determine the supply current, supply power factor, active and reactive power supplied and the value of the capacitances that must be connected in delta to improve the overall power factor to 0.95 lag. Obtain the result using (i) one phase of the three phase system, and (ii) the equivalent single phase circuit.

Solution

(i) Using one-phase diagram (figure 8)

$$Z_{L1} = 40 + j 30 \Omega$$

$$E_p = 400/\sqrt{3} = 230.9 \angle 0$$

$$P_p = 1.8/3 = 0.6 \text{ kW} = 600 \text{ W}$$

$$\therefore I_{p1} = \frac{230.9 \angle 0}{40 + j30} = \frac{230.9 \angle 0}{50 \angle 36.87^\circ} = 4.619 \angle -36.87^\circ$$

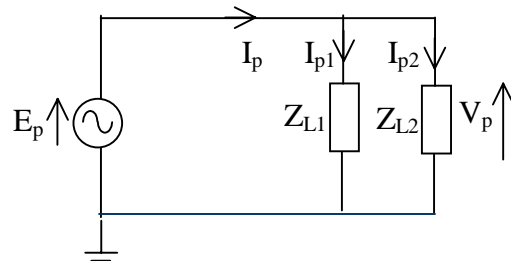

Figure 8 – Single phase diagram

[Note: Quite often, we take the phase voltage of the three phase 400 V system to be 230 V rather than the calculated value of 230.9 V. You would then of course get a slightly different answer.]

In order to calculate I_{p2} , we need not calculate Z_{L2} , but can use $P = V I \cos \phi$.

$$\therefore I_{p2} = \frac{600}{230.9 \times 1} = 2.598 \angle 0 \quad \text{[Note: angle is zero because it is purely resistive]}$$

$$\text{Thus } I_p = I_{p1} + I_{p2} = 4.619 \angle -36.87^\circ + 2.598 = 6.293 - j 2.771 = 6.876 \angle -23.77^\circ \text{ A}$$

$$\therefore \text{ supply current} = 6.876 \angle -23.77^\circ \text{ A}$$

$$\text{supply power factor} = \cos (0 - (-23.77)) = 0.915 \text{ lag}$$

$$\text{active power supplied} = \sqrt{3} V_L I_L \cos \phi = \sqrt{3} \times 400 \times 6.876 \times 0.915 = 4360 \text{ W}$$

$$\text{reactive power supplied} = \sqrt{3} V_L I_L \sin \phi = \sqrt{3} \times 400 \times 6.876 \times \sin (-23.77) = 1920 \text{ var}$$

The capacitances are connected to improve the power factor.

Why do we want to improve the power factor ? This is because of the power factor is low and to transfer the same amount of active power we need a greater amount of current which in term means a much greater amount of power losses in the system, since power loss is proportional to the square of the current.

Why do we use capacitors to correct the power factor ? This is because most normal loads have an inductive component (for example, a fan has a winding and a fluorescent lamp has a choke, both of which are basically inductors). We can compensate for the reactive power of an inductive reactance by the reactive power of a capacitive reactance.

In this particular example, we are required to improve the power factor to 0.95. Why to 0.95 ? Why not to 1.0, which would give the lowest power factor ? This is because improvement of power factor means additional capacitance. We try to use only so much capacitance as would give us a financial benefit. When we improve the power factor angle from -36.87° (corresponding to power factor = 0.8 lag) to -18.19° (corresponding to a power factor of 0.95) we get an improvement of $(0.95 - 0.8 = 0.15$ or $0.15/0.8 = 18.75\%)$. Whereas when we improve a similar amount of angle from -18.19° to 0° , we get an improvement of only $(1.0 - 0.95 = 0.05$ or $0.05/0.95 = 5.3\%)$. In fact if we improved a similar amount from -53.13° (corresponding to a power factor of 0.6) to -36.87° we get an even larger improvement $(0.8 - 0.6 = 0.2$ or $0.2/0.6 = 33.3\%)$. Thus we can see that as we come closer and closer to unity power factor, the benefits rapidly decrease. Thus in industry it is usual to improve the power factor to a value slightly less than unity power factor, and this value can be theoretically calculated using such information as the cost of capacitors, the electricity tariff etc.

Let us get back to doing the calculations. When the power factor is improved to 0.95 lag, using a pure capacitance, then the amount of active power does not change but remains the same as before. i.e. $P = 4.360$ kW. However, the reactive power will decrease such that the overall power factor is 0.95.

[0.95 is obviously power factor lag, as to correct to 0.95 power factor lead would be even more costly than to improve to unity power factor and hence would absolutely have no advantage]

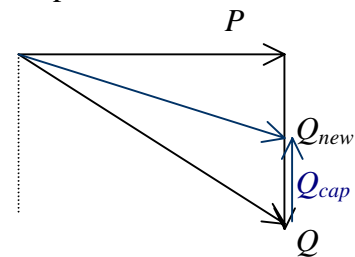

Figure 9 shows the diagram showing the active and reactive power during power factor correction.

Figure 9 – Power factor correction

The capacitance must add the difference between original amount of reactive power supplied and the new amount of reactive power supplied.

$$Q = 1.920 \text{ k var}$$

with the new power factor, Q_{new} is calculated from

$$Q_{new} = P \tan \phi_{new} = 4.360 \tan 18.19^\circ = 1.433 \text{ k var}$$

$$\therefore Q_{cap} = 1.920 - 1.433 = 0.487 \text{ k var}$$

each of the 3 capacitors would provide one-third this reactive power.

$$\therefore \text{Capacitance required} = 0.487/3 = 0.162 \text{ k var} = V^2 C \omega$$

If the capacitors are connected in delta, then the line voltage would appear across each.

$$\therefore 162 = 400^2 C 100 \pi$$

$$\therefore C = 3.230 \mu\text{F} \text{ each connected in delta}$$

If the capacitors are connected in star, then the phase voltage would appear across each.

$$\therefore 162 = 230.9^2 C 100 \pi$$

$$\therefore C = 9.689 \mu\text{F} \text{ each connected in star}$$

(ii) Using equivalent single-phase diagram (figure 9)

$$Z_{L1} = 40 + j 30 \Omega$$

$$E_L = 400 \angle 0$$

$$P = 1.8 \text{ kW} = 1800 \text{ W}$$

$$\therefore I_1 = \sqrt{3} I_{L1} = \frac{400 \angle 0}{40 + j30} = \frac{400 \angle 0}{50 \angle 36.87^\circ} = 8 \angle -36.87^\circ$$

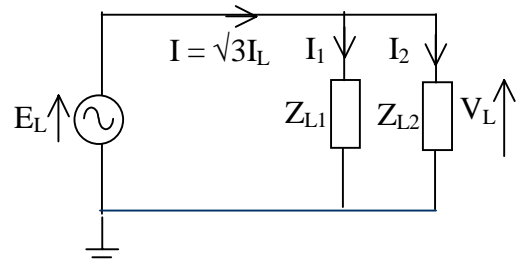

Figure 9 – Equivalent diagram

In order to calculate I_2 , we can use $P = \sqrt{3} V_L I_{L2} \cos \phi = V_L I_2 \cos \phi$.

$$\therefore I_2 = \frac{1800}{400 \times 1} = 4.5 \angle 0 \quad [\text{Note: angle is zero because it is purely resistive}]$$

Thus $\sqrt{3} I_L = I = I_1 + I_2 = 8 \angle -36.87^\circ + 4.5 = 10.9 - j 4.8 = 11.910 \angle -23.77^\circ \text{ A}$

$$\therefore \text{supply current} = 11.910 \angle -23.77^\circ / \sqrt{3} = 6.876 \angle -23.77^\circ \text{ A}$$

which is the same as in the earlier method. Remaining calculations will be similar.

Unbalanced three phase systems

An unbalanced three phase system is one which is not perfectly balanced. It may be caused by the supply being unbalanced, or more usually the load being unbalanced or both. In such a case, knowledge of the currents or voltages in one phase does not tell us the currents or voltages in the other phases. Thus all phase quantities must be independently determined. Let us consider some of the common unbalanced situations to see how this may be done.

(a) Star connected supply feeding a star connected load

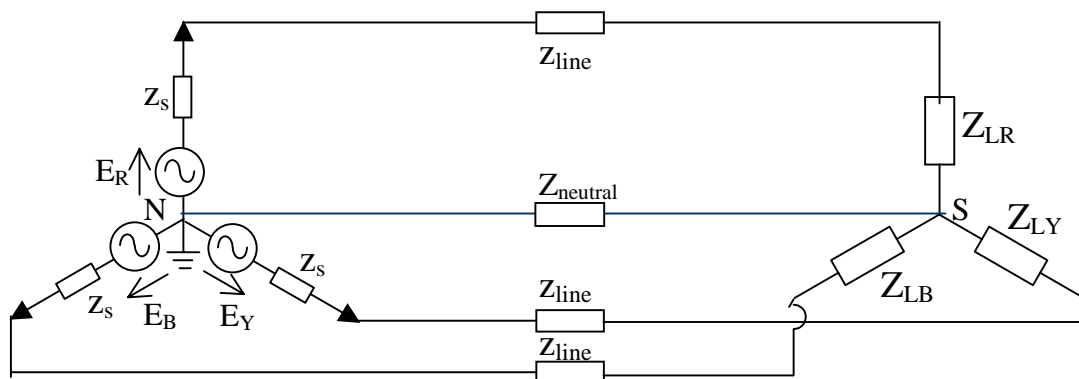

Figure 10 – Unbalanced Three phase system

(i) If $Z_{neutral}$ is considered zero, each individual phase current can be independently determined from the supply voltage in that phase and the impedance of that phase.

$$I_{LR} = \frac{E_R}{z_s + z_{line} + Z_{LR}}, \quad I_{LY} = \frac{E_Y}{z_s + z_{line} + Z_{LY}}, \quad I_{LB} = \frac{E_B}{z_s + z_{line} + Z_{LB}}$$

Then the load voltages etc can be determined.

(ii) If there is a neutral impedance, then using Millmann's theorem, we will first have to determine the voltage of the star point of the load with respect to the supply neutral.

$$V_{SN} = \frac{\sum Y.V}{Y} = \frac{\frac{1}{z_s + z_{line} + Z_{LR}} \cdot E_R + \frac{1}{z_s + z_{line} + Z_{LY}} \cdot E_Y + \frac{1}{z_s + z_{line} + Z_{LB}} \cdot E_B + \frac{1}{z_{neutral}} \cdot 0}{\frac{1}{z_s + z_{line} + Z_{LR}} + \frac{1}{z_s + z_{line} + Z_{LY}} + \frac{1}{z_s + z_{line} + Z_{LB}} + \frac{1}{z_{neutral}}}$$

from which V_{SN} is known.

Thus the load currents can be determined from

$$I_{LR} = \frac{E_R - V_{SN}}{z_s + z_{line} + Z_{LR}}, \quad I_{LY} = \frac{E_Y - V_{SN}}{z_s + z_{line} + Z_{LY}}, \quad I_{LB} = \frac{E_B - V_{SN}}{z_s + z_{line} + Z_{LB}}$$

Hence the remaining quantities can be determined.

(iii) If the system is a 3-wire system, rather than a 4-wire system, the analysis is the same as if $z_{neutral}$ were ∞ (i.e. $1/z_{neutral} = 0$). Thus again Millmann's theorem is used to determine V_{SN} and the load currents are then determined.

(b) Delta connected supply feeding a star connected load

If the supply was connected, not in star but in delta (figure 11), which is not the case in practice, then we would have to write the Kirchoff's current law for the loops and solve as a normal circuit problem.

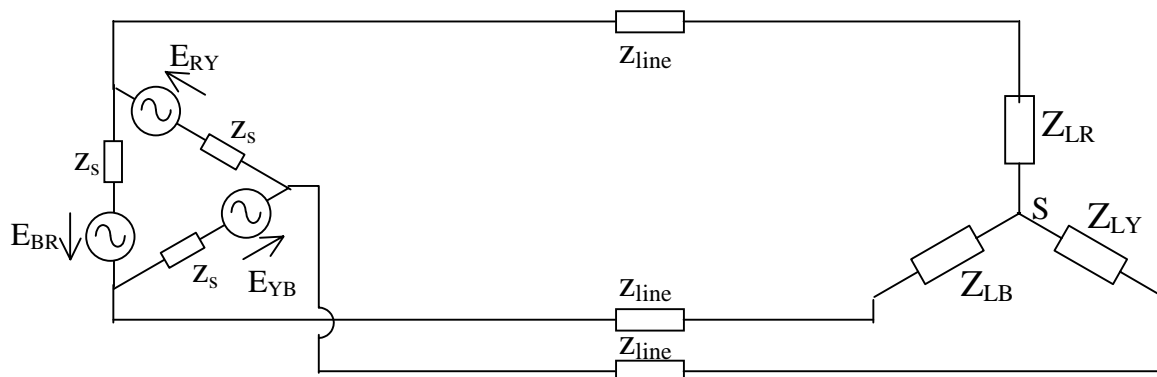

Figure 11 – Delta supply feeding star load

(c) Delta connected supply feeding a delta connected load

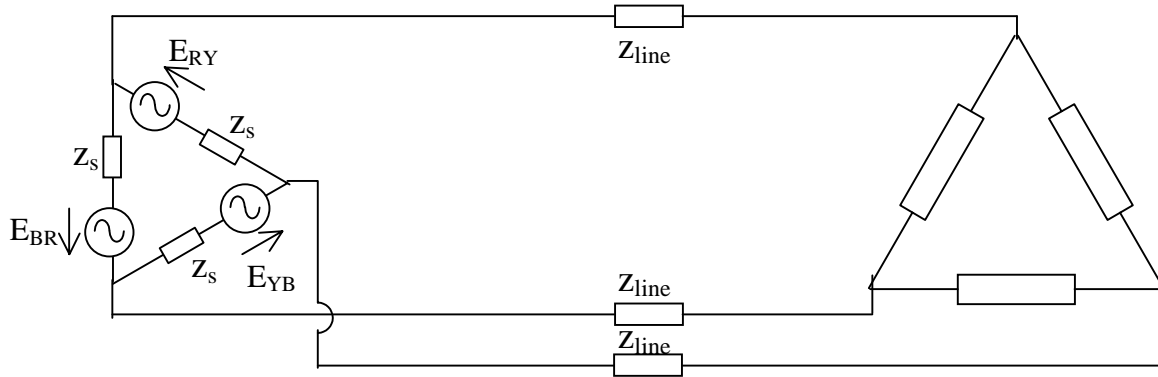

Figure 12 - Delta connected supply feeding a delta connected load

When a delta connected supply feeds a delta connected load (figure 12), which is not usual, then the line voltages are known so that the currents inside the delta can be obtained directly from Ohm's Law. The line currents can then be obtained by phasor summing of the currents inside the delta. The remaining variables are then obtained directly.

(d) Star connected supply feeding a delta connected load

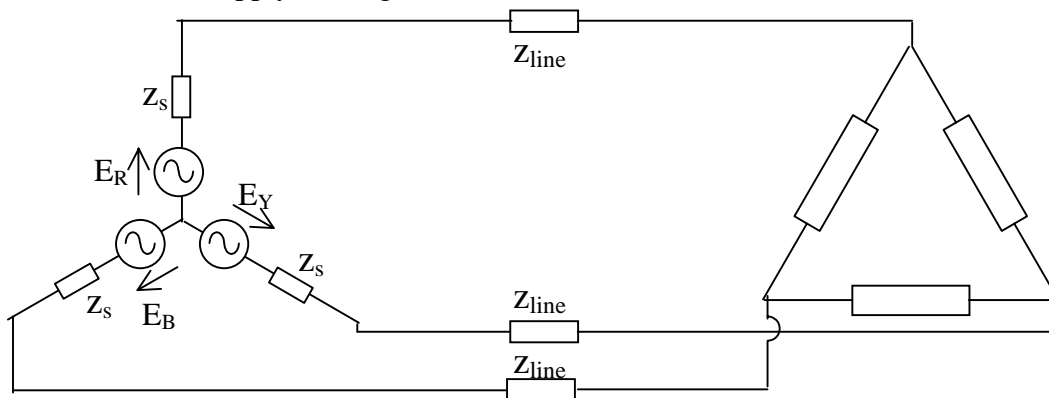

Figure 13 - Star connected supply feeding a delta connected load

When a star connected supply feeds a delta connected load (figure 13), then from the phase voltages the the line voltages are known so that the currents inside the delta can be obtained directly from Ohm's Law. The line currents can then be obtained by phasor summing of the currents inside the delta. The remaining variables are then obtained directly.

Thus basically, any unbalanced system can be calculated using the basic network theorems.

Symmetrical Components (or Sequence Components)

Phase Sequence

A three phase system of voltages (or currents) has a sequence (or order) in which the phases reach a particular position (for example peak value). This is the natural sequence of the supply. According to usual notation, we would call the sequence R-Y-B or A-B-C.

If we consider a balanced system of voltages (or currents) they will have only the natural sequence, and there will no other components present. However, Fortescue has formulated that any unbalanced system can be split up into a series of balanced systems.

[This is like saying that any force can be broken up into its components along the x-axis, y-axis and z-axis. The advantage of such a decomposition is in the analysis of more than one quantity]

In the case of unbalanced three phase system, such as shown in figure 14, the unbalanced system can be split up into 3 components: (i) a balanced system having the same phase sequence as the unbalanced system, (ii) a balanced system having the opposite phase sequence to the unbalanced system (rotation of phasors is always anticlockwise whether they are in the same sequence or opposite, so that it is the order of the phases that changes, and not the direction of rotation), and (iii) a balanced system of inphase quantities.

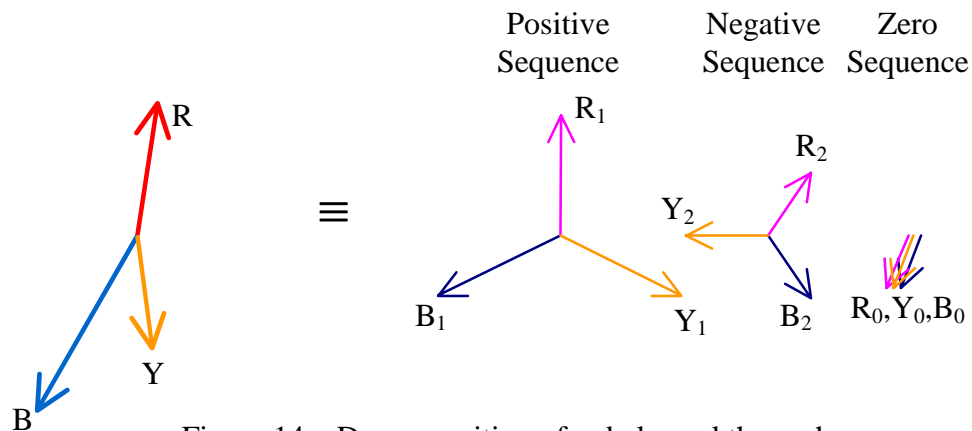

Figure 14 – Decomposition of unbalanced three phase

In any three phase system, the phase quantities **R**, **Y** and **B** (or A, B and C) may be expressed as the phasor sum of:

- a set of balanced positive phase sequence quantities **A₁**, **B₁** and **C₁**
(phase sequence a-b-c : same phase sequence as original unbalanced quantities),
- a set of balanced negative phase sequence currents **A₂**, **B₂** and **C₂**
(phase sequence a-c-b: opposite phase sequence to original unbalanced quantities),
- a set of identical zero phase sequence currents **A₀**, **B₀** and **C₀**
(inphase, no phase sequence).

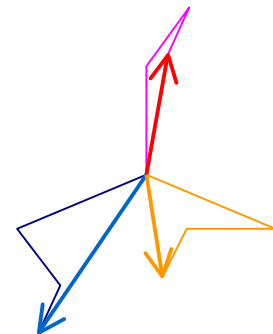

Figure 15 - Regrouping

It is to be noted that the original unbalanced system effectively has 3 complex unknown quantities **A**, **B** and **C** (magnitude and phase angle of each is independent).

It is also to be noted that each of the balanced components have only one independent complex unknown each, as the others can be written by symmetry. Thus the three sets of symmetrical components also have effectively 3 complex unknown quantities. These are usually selected as the components of the first phase **A** (i.e. **A**₀, **A**₁ and **A**₂). One of the other phases could have been selected as well, but all 3 components should be selected for the same phase.

A can be obtained by the phasor addition of **A**₀, **A**₁ and **A**₂. Similarly **B** and **C**. Thus

$$\begin{aligned} \mathbf{A} &= \mathbf{A}_0 + \mathbf{A}_1 + \mathbf{A}_2 \\ \mathbf{B} &= \mathbf{B}_0 + \mathbf{B}_1 + \mathbf{B}_2 \\ \mathbf{C} &= \mathbf{C}_0 + \mathbf{C}_1 + \mathbf{C}_2 \end{aligned}$$

If the balanced components are considered, we see that the most frequently occurring angle is 120°.

In complex number theory, we defined *j* as the complex operator which is equal to √-1 and a magnitude of unity, and more importantly, when operated on any complex number rotates it anti-clockwise by an angle of 90°.

$$\text{i.e. } j = \sqrt{-1} = 1 \angle 90^\circ$$

In like manner, we can define a new complex operator **α** which has a magnitude of unity and when operated on any complex number rotates it anti-clockwise by an angle of 120°.

$$\text{i.e. } \alpha = 1 \angle 120^\circ = -0.500 + j 0.866$$

Let us again examine the sequence components of the unbalanced quantity.

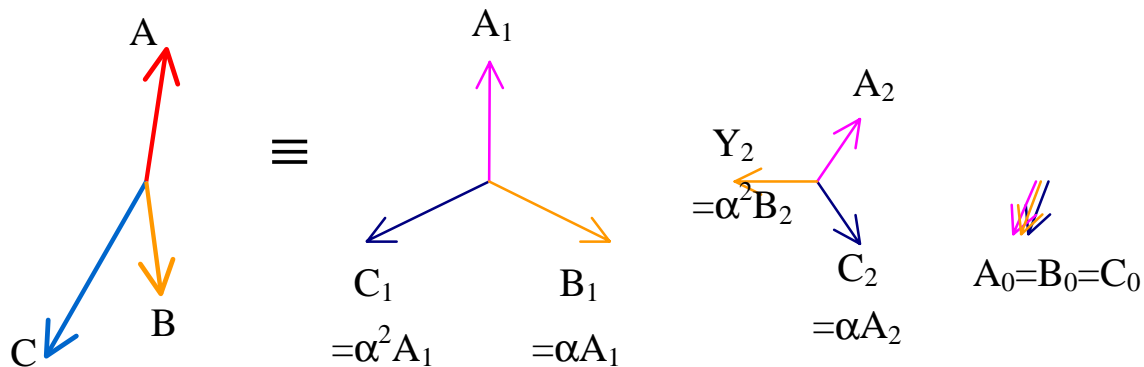

Figure 16 – Decomposition of unbalanced three phase

We can express all the sequence components in terms of the quantities for **A** phase using the properties of rotation of 0°, 120° or 240°. Thus

$$\begin{aligned} \mathbf{A} &= \mathbf{A}_0 + \mathbf{A}_1 + \mathbf{A}_2 \\ \mathbf{B} &= \mathbf{A}_0 + \alpha^2 \mathbf{A}_1 + \alpha \mathbf{A}_2 \\ \mathbf{C} &= \mathbf{A}_0 + \alpha \mathbf{A}_1 + \alpha^2 \mathbf{A}_2 \end{aligned}$$

This can be written in matrix form.

$$\begin{bmatrix} A \\ B \\ C \end{bmatrix} = \begin{bmatrix} 1 & 1 & 1 \\ 1 & \alpha^2 & \alpha \\ 1 & \alpha & \alpha^2 \end{bmatrix} \begin{bmatrix} A_0 \\ A_1 \\ A_2 \end{bmatrix}$$

$\underline{Ph} \qquad \qquad \qquad [\Lambda] \qquad \qquad \qquad \underline{Sy}$

This gives the basic symmetrical component matrix equation, which shows the relationship between the phase component vector \underline{Ph} and the symmetrical component vector \underline{Sy} using the symmetrical component matrix $[\Lambda]$. Both the phase component vector \underline{Ph} and the symmetrical component vector \underline{Sy} can be either voltages or currents, but in a particular equation, they must of course all be of the same type.

Since the matrix is a $[3 \times 3]$ matrix, it is possible to invert it and express \underline{Sy} in terms of \underline{Ph} . But to do this, it would be convenient to first express some properties of α .

Some Properties of α

$$\alpha = 1 \angle 2\pi/3 \text{ or } 1 \angle 120^\circ$$

$$\alpha^2 = 1 \angle 4\pi/3 \text{ or } 1 \angle 240^\circ \text{ or } 1 \angle -120^\circ$$

$$\alpha^3 = 1 \angle 2\pi \text{ or } 1 \angle 360^\circ \text{ or } 1$$

i.e. $\alpha^3 - 1 = (\alpha - 1)(\alpha^2 + \alpha + 1) = 0$

Since α is complex, it cannot be equal to 1, so that $\alpha - 1$ cannot be zero.

$$\therefore \alpha^2 + \alpha + 1 = 0$$

This also has the physical meaning that the three sides of an equilateral triangles must close.

Also $\alpha^{-1} = \alpha^2$ and $\alpha^{-2} = \alpha$

Now let us look at inverting the symmetrical component matrix.

Inverse of Symmetrical component matrix

$$[\Lambda] = \begin{bmatrix} 1 & 1 & 1 \\ 1 & \alpha^2 & \alpha \\ 1 & \alpha & \alpha^2 \end{bmatrix},$$

$$\begin{aligned} \text{so that } [\Lambda]^{-1} &= \begin{bmatrix} 1 & 1 & 1 \\ 1 & \alpha^2 & \alpha \\ 1 & \alpha & \alpha^2 \end{bmatrix}^{-1} = \frac{1}{\Delta} \begin{bmatrix} \alpha^4 - \alpha^2 & -(\alpha^2 - \alpha) & \alpha - \alpha^2 \\ -(\alpha^2 - \alpha) & \alpha^2 - 1 & 1 - \alpha \\ \alpha - \alpha^2 & 1 - \alpha & \alpha^2 - 1 \end{bmatrix} \\ &= \frac{1}{\Delta} \begin{bmatrix} \alpha - \alpha^2 & \alpha - \alpha^2 & \alpha - \alpha^2 \\ \alpha - \alpha^2 & \alpha^2 - 1 & 1 - \alpha \\ \alpha - \alpha^2 & 1 - \alpha & \alpha^2 - 1 \end{bmatrix} \end{aligned}$$

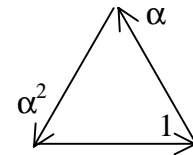

Figure 17 Phasor Addition

$$[\Lambda]^{-1} = \frac{1}{\Delta} \begin{bmatrix} \alpha(1-\alpha) & \alpha(1-\alpha) & \alpha(1-\alpha) \\ \alpha(1-\alpha) & -(1-\alpha)(\alpha+1) & 1-\alpha \\ \alpha(1-\alpha) & 1-\alpha & -(1-\alpha)(\alpha+1) \end{bmatrix}$$

and the discriminant $\Delta = 3(\alpha - \alpha^2) = 3\alpha(1-\alpha)$

Substituting, the matrix equation simplifies to give

$$[\Lambda]^{-1} = \frac{1}{3\alpha} \begin{bmatrix} \alpha & \alpha & \alpha \\ \alpha & -(\alpha+1) & 1 \\ \alpha & 1 & -(\alpha+1) \end{bmatrix}$$

Since $\alpha^{-1} = \alpha^2$, $\alpha^{-2} = \alpha$ and $1 + \alpha + \alpha^2 = 0$, the matrix equation further simplifies to

$$[\Lambda]^{-1} = \frac{1}{3} \begin{bmatrix} 1 & 1 & 1 \\ 1 & \alpha & \alpha^2 \\ 1 & \alpha^2 & \alpha \end{bmatrix}$$

It is seen that α is the complex conjugate of α^2 , and α^2 is the complex conjugate of α .

Thus the above matrix $[\Lambda]^{-1}$ is one-third of the complex conjugate of $[\Lambda]$.

i.e. $[\Lambda]^{-1} = \frac{1}{3} [\Lambda]^*$

This can now be written in the expanded form as

$$\begin{array}{ccc} \begin{bmatrix} A_0 \\ A_1 \\ A_2 \end{bmatrix} & = \frac{1}{3} \begin{bmatrix} 1 & 1 & 1 \\ 1 & \alpha & \alpha^2 \\ 1 & \alpha^2 & \alpha \end{bmatrix} \begin{bmatrix} A \\ B \\ C \end{bmatrix} \\ \underline{Sy} & & [\Lambda] \quad \underline{Ph} \end{array}$$

Example 1

Find the symmetrical components of the unbalanced system of the following voltages $1\angle 0^\circ$ V, $\sqrt{3}\angle -120^\circ$ V and $2\angle 90^\circ$ V.

Solution

Writing the matrix equation

$$\begin{bmatrix} V_{R0} \\ V_{R1} \\ V_{R2} \end{bmatrix} = \frac{1}{3} \begin{bmatrix} 1 & 1 & 1 \\ 1 & \alpha & \alpha^2 \\ 1 & \alpha^2 & \alpha \end{bmatrix} \begin{bmatrix} 1\angle 0^\circ \\ \sqrt{3}\angle -120^\circ \\ 2\angle 90^\circ \end{bmatrix}$$

Expanding the equation gives

$$\begin{aligned} V_{R0} &= \frac{1}{3} [1\angle 0^\circ + \sqrt{3}\angle -120^\circ + 2\angle 90^\circ] = \frac{1}{3} [1 - \sqrt{3}/2 - j3/2 + j2] = \frac{1}{3} [0.134 + j 0.5] \\ &= 0.045 + j 0.167 = 0.173\angle 75.0^\circ \text{ V} \end{aligned}$$

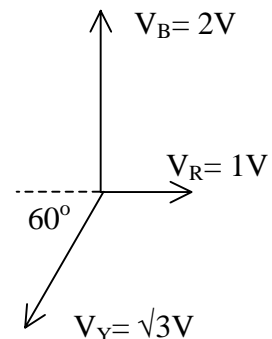

Figure 18 Unbalanced Phasors

$$V_{R1} = \frac{1}{3} [1\angle 0^\circ + 1\angle 120^\circ \times \sqrt{3}\angle -120^\circ + 1\angle 240^\circ \times 2\angle 90^\circ] = \frac{1}{3} [1 + \sqrt{3} + \sqrt{3} - j1]$$

$$= \frac{1}{3} [4.464 - j1] = 1.488 - j0.333 = 1.525\angle -12.6^\circ \text{ V}$$

$$V_{R2} = \frac{1}{3} [1\angle 0^\circ + 1\angle 240^\circ \times \sqrt{3}\angle -120^\circ + 1\angle 120^\circ \times 2\angle 90^\circ] = \frac{1}{3} [1 - \sqrt{3}/2 + j3/2 - \sqrt{3} - j1]$$

$$= \frac{1}{3} [-1.598 + j0.5] = -0.533 + j0.167 = 0.558\angle 162.6^\circ \text{ V}$$

Graphical Method of Solution

The method of determining the sequence components from the phase components and the phase components from the sequence components are similar except that the correct equation must be used.

The solution of the equations may also be done graphically. The advantage of a graphical solution is that it gives an insight to the components very quickly without the need of a rigorous analysis. In the graphical analysis, in addition to phasor addition, multiplication by α or α^2 would correspond to an anticlockwise rotation of 120° or 240° respectively.

This can be best understood by an example.

Example 2

For the unbalanced set of phasors shown in figure 19, verify graphically the sequence components obtained in example 1.

Solution

$$\begin{bmatrix} V_{R0} \\ V_{R1} \\ V_{R2} \end{bmatrix} = \frac{1}{3} \begin{bmatrix} 1 & 1 & 1 \\ 1 & \alpha & \alpha^2 \\ 1 & \alpha^2 & \alpha \end{bmatrix} \begin{bmatrix} V_R \\ V_Y \\ V_B \end{bmatrix}$$

$$V_{R0} = \frac{1}{3} [V_R + V_Y + V_B]$$

or $3V_{R0} = [V_R + V_Y + V_B]$

It is more common to plot $3V_{R0}$ rather than V_{R0} and to obtain one-third the result. This is shown in figure 20. It can be seen that the resultant has a magnitude of about half that of V_R (say 0.5) and an angle of slightly greater than that of the V_Y (say 75°). This corresponds to $3V_{R0}$.

If we compare the result with that of the analytical method in example 1, we see that the value for $3V_{R0}$ should be $3 \times 0.173\angle 75.0^\circ \text{ V}$ agreeing with the observation.

$$\text{Similarly, } V_{R1} = \frac{1}{3} [V_R + \alpha V_Y + \alpha^2 V_B]$$

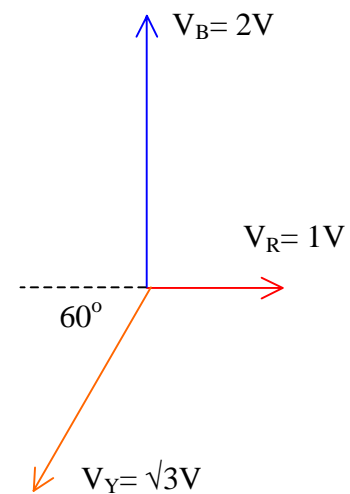

Figure 19 Unbalanced Phasors

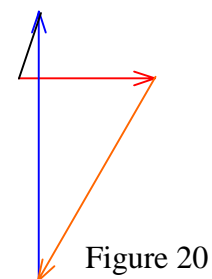

Figure 20

$$\text{or } 3V_{R1} = [V_R + \alpha V_Y + \alpha^2 V_B]$$

The phasor addition is shown in figure 21. It can be seen that the resultant has a magnitude of slightly greater than one and half times that of V_R & V_Y (say 4.2) together and an angle close to 15° below the horizontal axis. This corresponds to $3V_{R1}$.

If we compare the result with that of the analytical method in example 1, we see that the value for $3V_{R1}$ should be $3 \times 1.525 \angle -12.6^\circ$ V roughly agreeing with the observation.

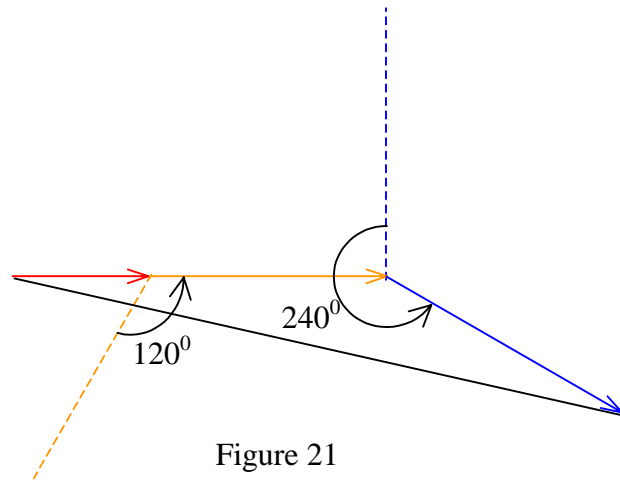

Figure 21

[An accurate result could have been obtained if actual measurements had been done].

Similarly the negative sequence can be obtained as follows.

$$V_{R1} = \frac{1}{3} [V_R + \alpha^2 V_Y + \alpha V_B]$$

$$\text{or } 3V_{R1} = [V_R + \alpha^2 V_Y + \alpha V_B]$$

This phasor addition is shown in figure 22. It can be seen that the resultant has a magnitude of slightly less than that of V_Y (say 1.7) together and an angle close to 15° above the negative horizontal axis. This corresponds to $3V_{R2}$.

If we compare the result with that of the analytical method in example 1, we see that the value for $3V_{R2}$ should be $3 \times 0.558 \angle 162.6^\circ$ V roughly agreeing with the observation.

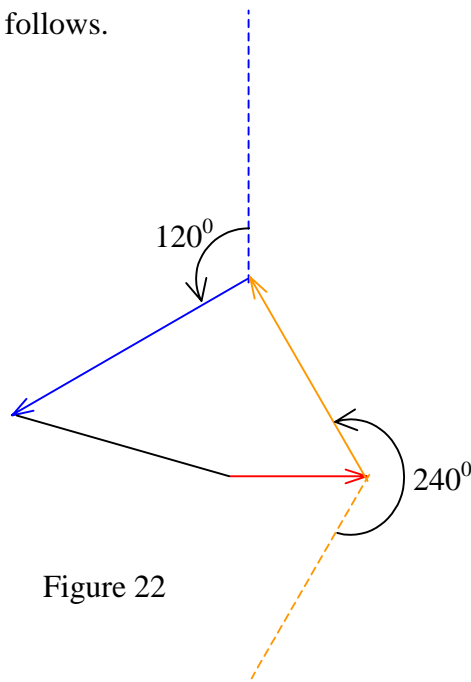

Figure 22

Summary

$$\underline{V}_p = [\Lambda] \underline{V}_s, \quad \underline{I}_p = [\Lambda] \underline{I}_s$$

$$\underline{V}_s = \frac{1}{3} [\Lambda]^* \underline{V}_p, \quad \underline{I}_s = \frac{1}{3} [\Lambda]^* \underline{I}_p$$

$$[\Lambda] = \begin{bmatrix} 1 & 1 & 1 \\ 1 & \alpha^2 & \alpha \\ 1 & \alpha & \alpha^2 \end{bmatrix}, \quad [\Lambda]^{-1} = \frac{1}{3} [\Lambda]^* = \frac{1}{3} \begin{bmatrix} 1 & 1 & 1 \\ 1 & \alpha & \alpha^2 \\ 1 & \alpha^2 & \alpha \end{bmatrix}$$

Sequence Impedances

Let us now consider how the impedance appears in sequence components.

To do this we must first look at the impedance matrix in phase components which we know.

$$\underline{V}_p = [Z_p] \cdot \underline{I}_p$$

Substituting for \underline{V}_p and \underline{I}_p in terms of the symmetrical components we have

$$[\Lambda] \underline{V}_s = [Z_p] \cdot [\Lambda] \underline{I}_s$$

pre-multiplying equation by $[\Lambda]^{-1}$ we have

$$\underline{V}_s = [\Lambda]^{-1} \cdot [Z_p] \cdot [\Lambda] \underline{I}_s$$

This gives the relationship between the symmetrical component voltage \underline{V}_s and the symmetrical component current \underline{I}_s , and hence defines the symmetrical component impedance matrix or Sequence Impedance matrix.

$$\text{Thus } [Z_s] = [\Lambda]^{-1} \cdot [Z_p] \cdot [\Lambda] = \frac{1}{3} [\Lambda]^* \cdot [Z_p] \cdot [\Lambda]$$

In a similar manner, we could express the phase component impedance matrix in terms of the symmetrical component impedance matrix as follows.

$$[Z_p] = [\Lambda] \cdot [Z_s] \cdot [\Lambda]^{-1} = \frac{1}{3} [\Lambda] \cdot [Z_s] \cdot [\Lambda]^*$$

The form of the sequence impedance matrix for practical problems gives one of the main reasons for use of symmetrical components in practical power system analysis.

If we consider the simple arrangement of a 3 phase transmission line (figure 23), we would have the equivalent circuit as

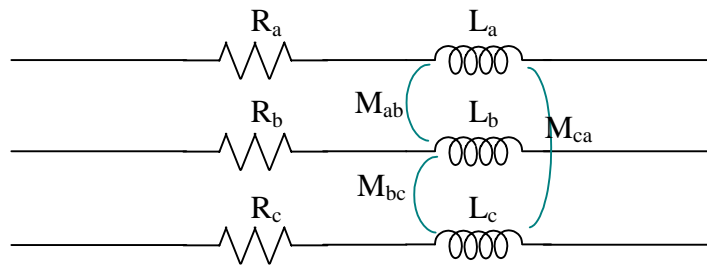

Figure 23 – 3 phase transmission line

If we think of an actual line such as from Victoria to Kotmale, we would realise that all 3 phase wires would have approximately the same length (other than due to differences in sagging) and hence we can assume the self impedance components to be equal for each phase.

$$\text{i.e. } R_a = R_b = R_c \text{ and } L_a = L_b = L_c$$

When a current passes in one phase conductor, there would be induced voltages in the other two phase conductors. In practice all three phase conductors behave similarly, so that we could consider the mutual coupling between phases also to be equal.

$$\text{i.e. } M_{ab} = M_{bc} = M_{ca}$$

In such a practical situation as above, the phase component impedance matrix would be fully symmetrical, and we could express them using a self impedance term Z_s and a mutual impedance term Z_m .

Thus we may write the phase component impedance matrix as

$$[Z_p] = \begin{bmatrix} z_s & z_m & z_m \\ z_m & z_s & z_m \\ z_m & z_m & z_s \end{bmatrix}$$

We may now write the symmetrical component impedance matrix as

$$\begin{aligned} [Z_s] &= \frac{1}{3} [\Lambda]^* \cdot [Z_p] [\Lambda] = \frac{1}{3} \begin{bmatrix} 1 & 1 & 1 \\ 1 & \alpha & \alpha^2 \\ 1 & \alpha^2 & \alpha \end{bmatrix} \begin{bmatrix} z_s & z_m & z_m \\ z_m & z_s & z_m \\ z_m & z_m & z_s \end{bmatrix} \begin{bmatrix} 1 & 1 & 1 \\ 1 & \alpha^2 & \alpha \\ 1 & \alpha & \alpha^2 \end{bmatrix} \\ &= \frac{1}{3} \begin{bmatrix} 1 & 1 & 1 \\ 1 & \alpha & \alpha^2 \\ 1 & \alpha^2 & \alpha \end{bmatrix} \begin{bmatrix} z_s + 2z_m & z_s + (\alpha + \alpha^2)z_m & z_s + (\alpha + \alpha^2)z_m \\ z_s + 2z_m & \alpha^2 z_s + (1 + \alpha)z_m & \alpha z_s + (1 + \alpha^2)z_m \\ z_s + 2z_m & \alpha z_s + (1 + \alpha^2)z_m & \alpha^2 z_s + (1 + \alpha)z_m \end{bmatrix} \end{aligned}$$

This can be simplified using the property $1 + \alpha + \alpha^2 = 0$ as follows

$$\begin{aligned} [Z_s] &= \frac{1}{3} \begin{bmatrix} 1 & 1 & 1 \\ 1 & \alpha & \alpha^2 \\ 1 & \alpha^2 & \alpha \end{bmatrix} \begin{bmatrix} z_s + 2z_m & z_s - z_m & z_s - z_m \\ z_s + 2z_m & \alpha^2(z_s - z_m) & \alpha(z_s - z_m) \\ z_s + 2z_m & \alpha(z_s - z_m) & \alpha^2(z_s - z_m) \end{bmatrix} \\ &= \frac{1}{3} \begin{bmatrix} 3(z_s + 2z_m) & 0 & 0 \\ 0 & (1 + \alpha^3 + \alpha^3)(z_s - z_m) & 0 \\ 0 & 0 & (1 + \alpha^3 + \alpha^3)(z_s - z_m) \end{bmatrix} \\ \text{i.e. } [Z_s] &= \begin{bmatrix} (z_s + 2z_m) & 0 & 0 \\ 0 & (z_s - z_m) & 0 \\ 0 & 0 & (z_s - z_m) \end{bmatrix} = \begin{bmatrix} Z_0 & 0 & 0 \\ 0 & Z_1 & 0 \\ 0 & 0 & Z_2 \end{bmatrix} \end{aligned}$$

We see an important result here. While the phase component impedance matrix was a full matrix, although it had completely symmetry, the sequence component impedance matrix is diagonal. The advantage of a diagonal matrix is that it allows decoupling for ease of analysis.

To understand the importance of decoupling (or a diagonal matrix), let us look at the following simple algebraic problem.

$$5x + 3y + 3z = 6$$

$$3x + 5y + 3z = 4$$

$$3x + 3y + 5z = -10$$

You can see that there is a lot of symmetry in the problem, if formulated as a matrix equation.

$$\begin{bmatrix} 5 & 3 & 3 \\ 3 & 5 & 3 \\ 3 & 3 & 5 \end{bmatrix} \begin{bmatrix} x \\ y \\ z \end{bmatrix} = \begin{bmatrix} 6 \\ 4 \\ -10 \end{bmatrix}$$

However, I am almost sure you would not be able to give the solution $x = 3, y = 2, z = -5$ of this equation mentally.

However if I give you the following set of equations

$$4x + 0y + 0z = 12$$

$$0x + 5y + 0z = 10$$

$$0x + 0y + 3z = -15$$

which corresponds to a diagonal matrix, I am sure all of you would have been able to get the correct solution mentally and in a flash. This is because the solution of x requires only the first equation, that of y requires only the second equation and that of z only the third equation.

Power associated with Sequence Components

With phase components, power in a single phase is expressed as

$$P_{\text{phase}} = V I \cos \phi$$

Thus in three phase, we may either write $P = \sqrt{3} V_L I_L \cos \phi = 3 V_p I_p \cos \phi$ for a balanced three phase system. However, with an unbalanced system this is not possible and we would have to write the power as the addition of the powers in the three phases.

$$\text{Thus Apparent Complex Power } S = V_a I_a^* + V_b I_b^* + V_c I_c^*$$

The active power P is obtained as the Real part of the complex variable S .

This equation may be re-written in matrix form as follows.

$$S = \begin{bmatrix} V_a & V_b & V_c \end{bmatrix} \begin{bmatrix} I_a^* \\ I_b^* \\ I_c^* \end{bmatrix} = \underline{V}_p^T \cdot \underline{I}_p^*$$

Let us now convert it to symmetrical components, as follows.

$$S = \underline{V}_p^T \cdot \underline{I}_p^* = \underline{[\Lambda]} \underline{V}_s^T \cdot \underline{[\Lambda]} \underline{I}_s^*$$

which may be expanded as follows.

$$S = \underline{V}_s^T \underline{[\Lambda]} \underline{[\Lambda]}^T \cdot \underline{[\Lambda]} \underline{I}_s^* = \underline{V}_s^T \underline{[\Lambda]} \underline{[\Lambda]}^{-1} \underline{I}_s^* = 3 \underline{V}_s^T \cdot \underline{I}_s^*$$

$$\text{i.e. } S = 3 (V_{a0} I_{a0}^* + V_{a1} I_{a1}^* + V_{a2} I_{a2}^*)$$

This result can also be expected, as there are 3 phases in each of the sequence components taking the same power.

$$\text{Thus } P = 3 (V_{a0} I_{a0} \cos \phi_0 + V_{a1} I_{a1} \cos \phi_1 + V_{a2} I_{a2} \cos \phi_2)$$